

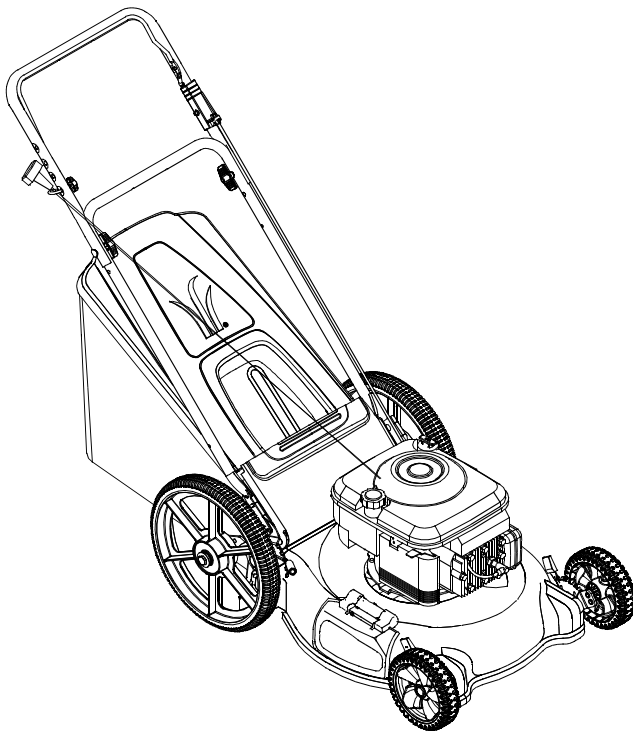

OPERATOR'S MANUAL



**21" Rear & Side
Discharge
Mulching Mower
Model Series 540**



IMPORTANT: READ SAFETY RULES AND INSTRUCTIONS CAREFULLY

Warning: This unit is equipped with an internal combustion engine and should not be used on or near any unimproved forest-covered, brush-covered or grass-covered land unless the engine's exhaust system is equipped with a spark arrester meeting applicable local or state laws (if any). If a spark arrester is used, it should be maintained in effective working order by the operator. In the State of California the above is required by law (Section 4442 of the California Public Resources Code). Other states may have similar laws. Federal laws apply on federal lands. A spark arrester for the muffler is available through your nearest engine authorized service dealer or contact the service department, P.O. Box 368022 Cleveland, Ohio 44136-9722.

MTD PRODUCTS INC. P.O. BOX 368022 CLEVELAND, OHIO 44136-9722

TABLE OF CONTENTS

Content	Page
Important Safe Operation Practices.....	3
Slope Gauge.....	6
Assembling Your Lawn Mower.....	7
Know Your Lawn Mower	9
Operating Your Lawn Mower	9
Making Adjustments	10
Maintaining Your Lawn Mower.....	11
Troubleshooting.....	14
Parts List.....	16

FINDING MODEL NUMBER

This Operator's Manual is an important part of your new lawn mower. It will help you assemble, prepare and maintain the unit for best performance. Please read and understand what it says.



Before you start assembling your new equipment, please locate the model plate on the equipment and copy the information from it in the space provided below. The information on the model plate is very important if you need help from our Customer Support Department or an authorized dealer.

- You can locate the model number by standing at the operating position and looking down at the rear of the mower deck. A sample model plate is explained below. For future reference, please copy the model number and the serial number of the equipment in the space below.

_____	_____
(Model Number)	(Serial Number)

 **MTD PRODUCTS INC**
CLEVELAND, OHIO 44136

Copy the model number here: _____

Copy the serial number here: _____

CALLING CUSTOMER SUPPORT

If you have difficulty assembling this product or have any questions regarding the controls, operation or maintenance of this unit, please call the Customer Support Department.



Call **1- (330) 220-4MTD (4683)** or **1- (800)-800-7310** to reach a Customer Support representative. Please have your unit's model number and serial number ready when you call. See previous section to locate this information. You will be asked to enter the serial number in order to process your call.

For more details about your unit, visit our website at www.mtdproducts.com

SECTION 1: IMPORTANT SAFE OPERATION PRACTICES



WARNING: This symbol points out important safety instructions which, if not followed, could endanger the personal safety and/or property of yourself and others. Read and follow all instructions in this manual before attempting to operate this machine. Failure to comply with these instructions may result in personal injury. When you see this symbol - **heed its warning.**

WARNING: Engine Exhaust, some of its constituents, and certain vehicle components contain or emit chemicals known to State of California to cause cancer and birth defects or other reproductive harm.

DANGER: This machine was built to be operated according to the rules for safe operation in this manual. As with any type of power equipment, carelessness or error on the part of the operator can result in serious injury. This machine is capable of amputating hands and feet and throwing objects. Failure to observe the following safety instructions could result in serious injury or death.

General Operation

1. Read this operator's manual carefully in its entirety before attempting to assemble this machine. Read, understand, and follow all instructions on the machine and in the manual(s) before operation. Be completely familiar with the controls and the proper use of this machine before operating it. Keep this manual in a safe place for future and regular reference and for ordering replacement parts.
2. This machine is a precision piece of power equipment, not a plaything. Therefore, exercise extreme caution at all times. Your unit has been designed to perform one job: to mow grass. Do not use it for any other purpose.
3. Never allow children under 14 years old to operate this machine. Children 14 years old and over should read and understand the operation instructions and safety rules in this manual and should be trained and supervised by a parent. Only responsible individuals who are familiar with these rules of safe operation should be allowed to use this machine.
4. Thoroughly inspect the area where the equipment is to be used. Remove all stones, sticks, wire, bones, toys and other foreign objects which could be tripped over or picked up and thrown by the blade. Thrown objects can cause serious personal injury. Plan your mowing pattern to avoid discharge of material toward roads, sidewalks, bystanders and the like. Also, avoid discharging material against a wall or obstruction which may cause discharged material to ricochet back toward the operator.
5. To help avoid blade contact or a thrown object injury, stay in the operator zone behind the handles and keep children, bystanders, helpers and pets at least 75 feet from the mower while it is in operation. Stop machine if anyone enters the area.
6. Always wear safety glasses or safety goggles during operation and while performing an adjustment or repair to protect your eyes. Thrown objects which ricochet can cause serious injury to the eyes.
7. Wear sturdy, rough-soled work shoes and close-fitting slacks and shirts. Shirts and pants that cover the arms and legs and steel-toed shoes are recommended. Never operate this machine in bare feet, sandals, slippery or light weight (e.g. canvas) shoes.
8. Do not put hands or feet near rotating parts or under the cutting deck. Contact with the blade can amputate hands and feet.
9. A missing or damaged discharge cover can cause blade contact or thrown object injuries.
10. Many injuries occur as a result of the mower being pulled over the foot during a fall caused by slipping or tripping. Do not hold on to the mower if you are falling; release the handle immediately.
11. Never pull the mower back toward you while you are walking. If you must back the mower away from a wall or obstruction first look down and behind to avoid tripping and then follow these steps:
 - a. Step back from the mower to fully extend your arms.
 - b. Be sure you are well balanced with sure footing.
 - c. Pull the mower back slowly, no more than half way toward you.
 - d. Repeat these steps as needed.
12. Do not operate the mower while under the influence of alcohol or drugs.
13. Do not engage the self-propelled mechanism on units so equipped while starting engine.
14. The blade control handle is a safety device. Never attempt to bypass its operation. Doing so makes the safety device inoperative and may result in personal injury through contact with the rotating blade. The blade control handle must operate easily in both directions and automatically return to the disengaged position when released.
15. Never operate the mower in wet grass. Always be sure of your footing. A slip and fall can cause serious personal injury. If you feel you are losing your footing, release the blade control handle immediately and the blade will stop rotating within three seconds.
16. Mow only in daylight or in good artificial light. Walk, never run.
17. Stop the blade when crossing gravel drives, walks or roads.
18. If the equipment should start to vibrate abnormally, stop the engine and check immediately for the cause. Vibration is generally a warning of trouble.
19. Shut the engine off and wait until the blade comes to a complete stop before removing the grass catcher or

unclogging the chute. The cutting blade continues to rotate for a few seconds after the engine is shut off.

Never place any part of the body in the blade area until you are sure the blade has stopped rotating.

20. Never operate mower without proper trail shield, discharge cover, grass catcher, blade control handle or other safety protective devices in place and working. Never operate mower with damaged safety devices. Failure to do so, can result in personal injury.
21. Muffler and engine become hot and can cause a burn. Do not touch.
22. Only use parts and accessories made for this machine by the manufacturer. Failure to do so, can result in personal injury.
23. If situations occur which are not covered in this manual, use care and good judgment. Contact your dealer for assistance. Telephone 1-800-800-7310 for the name of your nearest dealer.

Slope Operation

Slopes are a major factor related to slip and fall accidents which can result in severe injury. Operation on slopes requires extra caution. If you feel uneasy on a slope, do not mow it. For your safety, use the slope gauge included as part of this manual to measure slopes before operating this unit on a sloped or hilly area. If the slope is greater than 15 degrees, do not mow it.

Do:

1. Mow across the face of slopes; never up and down. Exercise extreme caution when changing direction on slopes.
2. Watch for holes, ruts, rocks, hidden objects, or bumps which can cause you to slip or trip. Tall grass can hide obstacles.
3. Always be sure of your footing. A slip and fall can cause serious personal injury. If you feel you are losing your balance, release the blade control handle immediately, and the blade will stop rotating within 3 seconds.

Do Not:

1. Do not mow near drop-offs, ditches or embankments, you could lose your footing or balance.
2. Do not mow slopes greater than 15 degrees as shown on the slope gauge.
3. Do not mow on wet grass. Unstable footing could cause slipping.

Children

Tragic accidents can occur if the operator is not alert to the presence of children. Children are often attracted to the mower and the mowing activity. They do not understand the dangers. Never assume that children will remain where you last saw them.

1. Keep children out of the mowing area and under the watchful care of a responsible adult other than the operator.
2. Be alert and turn mower off if a child enters the area.
3. Before and while moving backwards, look behind and down for small children.
4. Use extreme care when approaching blind corners, doorways, shrubs, trees, or other objects that may

obscure your vision of a child who may run into the mower.

5. Keep children away from hot or running engines. They can suffer burns from a hot muffler.
6. Never allow children under 14 years old to operate a power mower. Children 14 years old and over should read and understand the operation instructions and safety rules in this manual and should be trained and supervised by a parent.

Service

Safe Handling Of Gasoline:

1. To avoid personal injury or property damage use extreme care in handling gasoline. Gasoline is extremely flammable and the vapors are explosive. Serious personal injury can occur when gasoline is spilled on yourself or your clothes which can ignite.
2. Wash your skin and change clothes immediately.
3. Use only an approved gasoline container.
4. Never fill containers inside a vehicle or on a truck or trailer bed with a plastic liner. Always place containers on the ground away from your vehicle before filling.
5. When practical, remove gas-powered equipment from the truck or trailer and refuel it on the ground. If this is not possible, then refuel such equipment on a trailer with a portable container, rather than from a gasoline dispenser nozzle.
6. Keep the nozzle in contact with the rim of the fuel tank or container opening at all times until fueling is complete. Do not use a nozzle lock-open device.
7. Extinguish all cigarettes, cigars, pipes and other sources of ignition.
8. Never fuel machine indoors because flammable vapors will accumulate in the area.
9. Never remove gas cap or add fuel while the engine is hot or running. Allow engine to cool at least two minutes before refueling.
10. Never over fill fuel tank. Fill tank to no more than ½ inch below bottom of filler neck to provide space for fuel expansion.
11. Replace gasoline cap and tighten securely.
12. If gasoline is spilled, wipe it off the engine and equipment. Move unit to another area. Wait 5 minutes before starting the engine.
13. Never store the machine or fuel container inside where there is an open flame, spark or pilot light as on a water heater, space heater, furnace, clothes dryer or other gas appliances.
14. To reduce fire hazard, keep mower free of grass, leaves, or other debris build-up. Clean up oil or fuel spillage and remove any fuel soaked debris.
15. Allow a mower to cool at least 5 minutes before storing.

General Service:

1. Never run an engine indoors or in a poorly ventilated area. Engine exhaust contains carbon monoxide, an odorless and deadly gas.
2. Before cleaning, repairing, or inspecting, make certain the blade and all moving parts have stopped. Disconnect the spark plug wire and ground against the engine to prevent unintended starting.
3. Check the blade and engine mounting bolts at frequent

intervals for proper tightness. Also, visually inspect blade for damage (e.g., bent, cracked, worn) Replace blade with the original equipment manufacturer's (O.E.M.) blade only, listed in this manual. "Use of parts which do not meet the original equipment specifications may lead to improper performance and compromise safety!"

4. Mower blades are sharp and can cut. Wrap the blade or wear gloves, and use extra caution when servicing them.
5. Keep all nuts, bolts, and screws tight to be sure the equipment is in safe working condition.
6. Never tamper with safety devices. Check their proper operation regularly.
7. After striking a foreign object, stop the engine, disconnect the spark plug wire and ground against the engine. Thoroughly inspect the mower for any damage. Repair the damage before starting and operating the mower.
8. Never attempt to make a wheel or cutting height adjustment while the engine is running.
9. Grass catcher components, discharge cover, and trail shield are subject to wear and damage which could expose moving parts or allow objects to be thrown. For safety protection, frequently check components and replace immediately with original equipment manufacturer's (O.E.M.) parts only, listed in this manual. "Use of parts which do not meet the original equipment specifications may lead to improper performance and compromise safety!"
10. Do not change the engine governor setting or overspeed the engine. The governor controls the maximum safe operating speed of the engine.
11. Maintain or replace safety and instruction labels, as necessary.
12. Observe proper disposal laws and regulations. Improper disposal of fluids and materials can harm the environment.



WARNING - YOUR RESPONSIBILITY: Restrict the use of this power machine to persons who read, understand and follow the warnings and instructions in this manual and on the machine.

NOTE: Not all safety labels shown may apply to your lawn mower.



SECTION 2: SLOPE GAUGE

Use this page as a guide to determine slopes where you may not operate safely. **Do not operate** your lawn mower on such slopes.

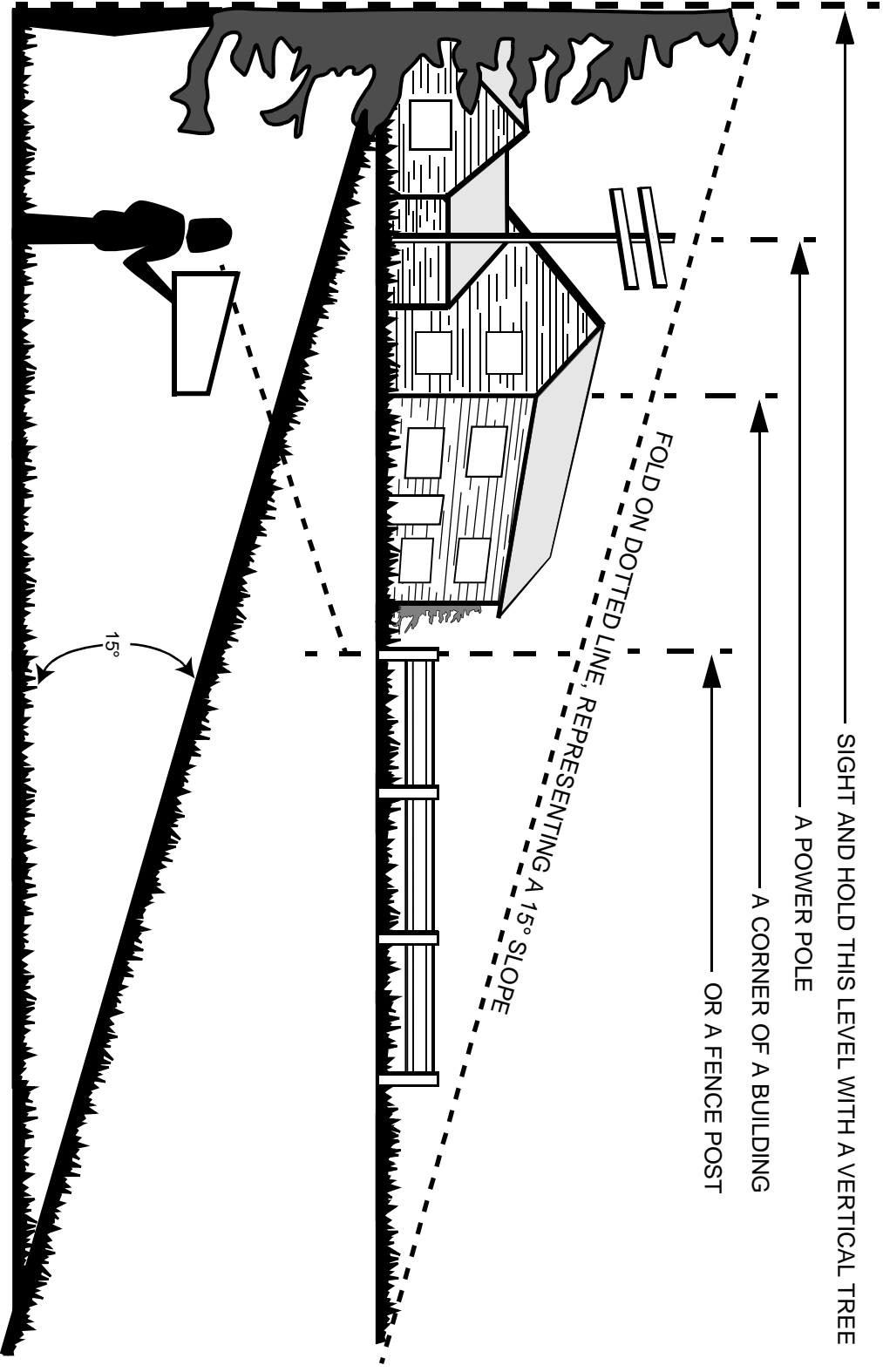

WARNING

Do not mow on inclines with a slope in excess of 15 degrees (a rise of approximately 2-1/2 feet every 10 feet). A riding mower could overturn and cause serious injury. If operating a walk-behind mower on such a slope, it is extremely difficult to maintain your footing and you could slip, resulting in serious injury. Operate RIDING mowers up and down slopes, never across the face of slopes. Operate WALK-BEHIND mowers across the face of slopes, never up and down slopes.

SECTION 3: ASSEMBLING YOUR LAWN MOWER

IMPORTANT: This unit is shipped without gasoline or oil in the engine. Be certain to service engine with gasoline and oil as instructed in the separate engine manual before operating your mower.

NOTE: Reference to right or left hand side of the mower is observed from the operating position.

Removing Unit From Carton

- Remove staples, break glue on top flaps, or cut tape at carton end and peel along top flap to open carton.
- Remove loose parts if included with unit (i.e., operator's manual, etc.)
- Cut along corners, lay carton down flat, and remove packing material.
- Roll or slide unit out of carton and check carton thoroughly for loose parts.

Loose Parts in Carton

- Grass Bag
- Side Discharge Chute
- Hardware Pack

Disconnecting Spark Plug Wire

Before setting up your lawn mower, disconnect the spark plug wire from the spark plug and ground against the engine. See Figure 1.

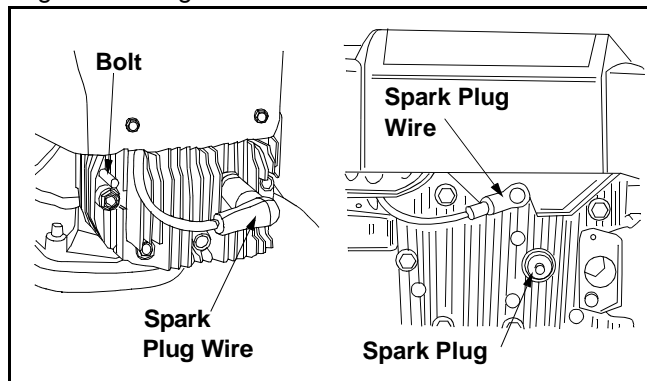

Figure 1

Setting Up Your Lawn Mower

Assembling Handle

- Lift up and pull back on the upper handle to raise the handle into the operating position. Make certain the lower handle is seated securely into the handle bracket assemblies. Tighten the wing nuts on each side of the handle (carriage bolts must be seated properly into the handle). See Figure 2.

NOTE: Your mower is shipped with the handle in the higher position. If you wish to lower the height of the handle, refer to the Adjustment Section at this time.

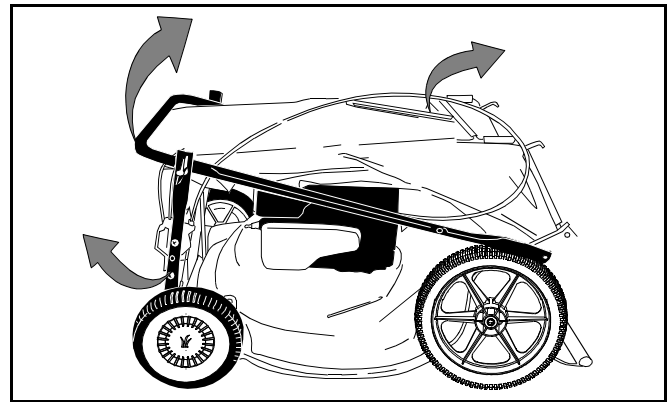

Figure 2

- Remove the hairpin clips from the outer hole in the weld pins on the handle mounting brackets. Using a pair of pliers, squeeze one leg of the lower handle against the handle mounting bracket. Insert the hairpin clip into the inner hole on the weld pin. Repeat on the other side. See Figure 3.
- After moving the hairpin clip, insert the carriage bolt from hardware pack in the upper hole on the handle mounting bracket and secure with plastic wing nut from the hardware pack. Repeat on other side.

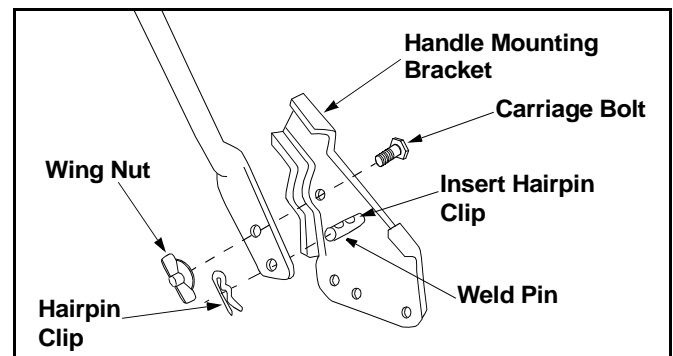

Figure 3

- Fasten the cable to the lower handle with the two cable ties found on the lower handle. Pull the cable ties tight and trim off the excess. See Figure 4.

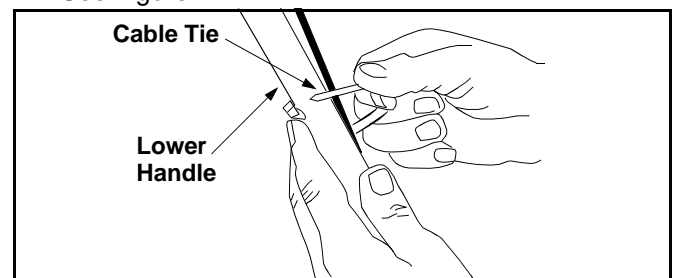

Figure 4

Attaching Starter Rope

- The rope guide is attached to the right side of upper handle. Loosen the wing nut which secures the rope guide. See Figure 5.

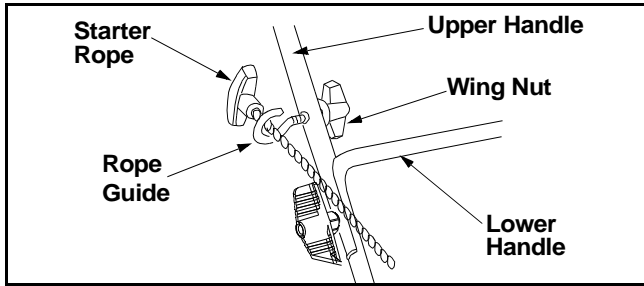

Figure 5

- With the spark plug wire disconnected and grounded, hold the blade control handle against the upper handle, and pull the starter rope out of the engine. Release the blade control handle. Slip the starter rope into the rope guide. Tighten the wing nut.

Attaching Grass Catcher To Mower

NOTE: The mulching baffle, if so equipped, is already in place on the mower for shipping purposes. Your lawn mower may be equipped with both a mulching baffle and a mulching plug. While the mulching baffle is located at the rear of the mower, the mulching plug is located on the right side of the cutting deck. Do not remove the mulching plug from the mower even when you are not mulching the grass.

- To remove the mulching baffle, lift the rear discharge door on the mower. Remove the mulching baffle. See Figure 6.

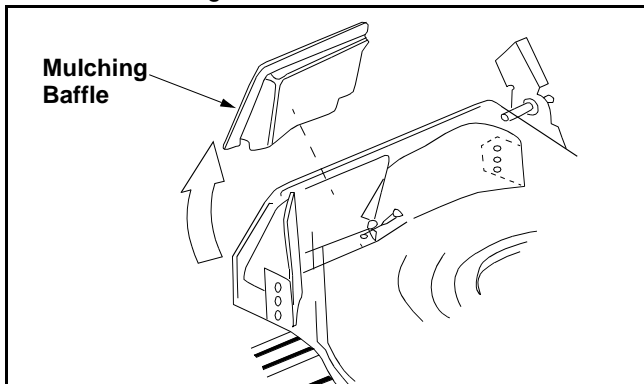

Figure 6

IMPORTANT: Make sure cables are routed to the outside of the handle so they are not in the way when attaching the grass catcher.

- Lift the rear discharge door on the mower.
- Place the hooks, found on both sides of the grass catcher frame, over the chute door pivot rod at the rear of the mower. Release the rear discharge door. See Figure 7.

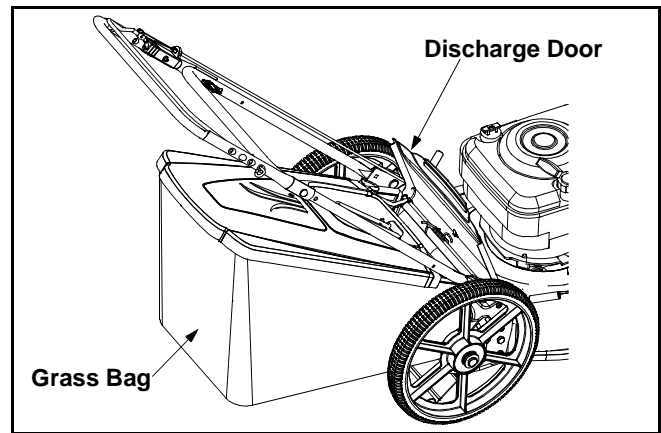

Figure 7

- To remove the grass catcher, lift the rear discharge door on the mower, lift the grass catcher up and off the pivot rod. Reinstall the mulching baffle and release the rear discharge door.



WARNING: Never operate the mower unless the hooks on the grass catcher are firmly seated on the chute pivot rod, and the rear discharge door rests firmly against the top of the grass catcher.

Converting To Side Discharge

If your unit is equipped with a side discharge chute, you can convert to a side discharge mower as follows:

- Lift the rear discharge door and install the mulching baffle. See Figure 6.
- On the side of the mower, lift the mulching plug and slide the two hooks of the side discharge chute under the hinge pin on the mulching plug assembly. Lower the side mulching plug. See Figure 8.
- Do not remove the side mulching plug at any time, even when you are not mulching.

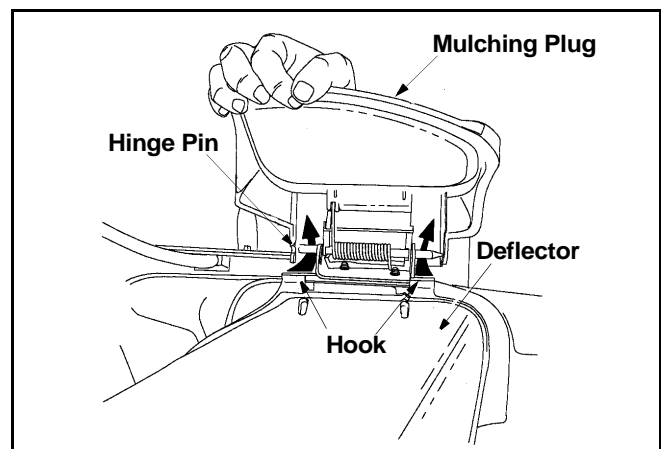

Figure 8

SECTION 4: KNOW YOUR LAWN MOWER

Read this operator's manual and safety rules before operating your lawn mower. Compare the illustration in Figure 9 with your lawn mower to familiarize yourself with the location of various controls and adjustments. Save this manual for future reference.



WARNING: The operation of any lawn mower can result in foreign objects being thrown into the eyes, which can damage your eyes severely. Always wear safety glasses while operating the mower, or while performing any adjustments or repairs on it.

Recoil Starter

The recoil starter is attached to the right handle. Stand behind the unit and pull the recoil starter to start the unit. See Figure 9.

Blade Control Handle

The blade control handle is located on the upper handle of the mower. The blade control handle must be depressed in order to operate the unit. Release blade control handle to stop engine and blade. See Figure 9.



WARNING: This blade control mechanism is a safety device. Never attempt to bypass its operations.

Cutting Height Adjustment Levers

These levers are located on each wheel and are used to adjust the cutting height. These levers have to be at the same relative position to ensure uniform cut. See Figure 9.

Grass Catcher

The grass catcher, located at the rear of the mower, is used to bag the grass clippings for disposal at another site. Once the bag is full, it has to be removed from the mower and emptied before any further mowing.

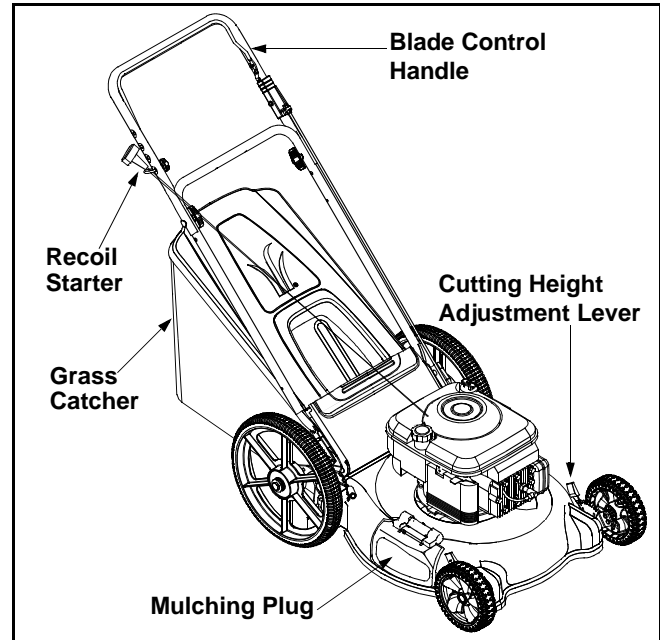

Figure 9

Mulching Plug

Both the mulching baffle and the mulching plug are used only for mulching purposes. Instead of collecting the grass clippings in a grass catcher, some mower models have the option of recirculating the clippings back to the lawn.

SECTION 5: OPERATING YOUR LAWN MOWER



WARNING: Keep hands and feet away from chute area on the cutting deck. The operation of any lawn mower can result in foreign objects being thrown into the eyes, which can result in severe eye damage. Always wear safety glasses or eye shields.

NOTE: For shipping purposes your mower is set with the wheels in a low cutting height position. For best results raise the cutting position until it is determined which height is best for your lawn. See the Adjustment Section for details.

Gas and Oil Fill-Up

Service the engine with gasoline and oil as instructed in the separate engine manual packed with your mower. Read instructions carefully.



Never fill fuel tank indoors with engine running or until the engine has been allowed to cool for at least two minutes after running.

Starting Engine

- Attach spark plug wire to spark plug. Make certain the metal cap on the end of the spark plug is fastened securely over the metal tip on the spark plug.
- Prime engine as instructed in the separate engine manual packed with your unit.
- Your lawn mower may be equipped with a constant speed throttle, which is set at full throttle for best performance.

- Stand behind the mower and squeeze the blade control handle against the upper handle.
- Grasp recoil starter handle and pull rope out slowly until engine reaches the start of compression cycle (rope will pull slightly harder at this point). Let the rope rewind slowly. Pull rope with a rapid, continuous, full arm stroke. Keeping a firm grip on the starter handle, let the rope return to the starter slowly.

Using Your Lawn Mower

Be sure that the lawn is clear of stones, sticks, wire, or other objects which could damage the lawn mower or the engine. Such objects could be accidentally thrown by the mower in any direction and cause serious personal injury to the operator and others.

For best results, do not cut wet grass because it tends to stick to the underside of the mower, preventing proper discharge of grass clippings, and could cause you to slip and fall. New grass, thick grass, or wet grass may require a narrower cut.

For a healthier lawn, never cut off more than one-third of the total length of the grass. Your lawn should be cut in the fall as long as there is growth. This mower is

designed to be operated at full throttle to give you the best cut and do the most effective job of mowing or mulching.



WARNING: If you strike a foreign object, stop the engine. Remove wire from the spark plug, thoroughly inspect the mower for any damage, and repair the damage before restarting and operating the mower. Extensive vibration of the mower during operation is an indication of damage. The unit should be promptly inspected and repaired.

Mulching

For effective mulching, do not cut wet grass because it tends to stick to the underside of the deck, preventing proper mulching of grass clippings. New or thick grass may require a narrower cut. The ground speed should be adjusted to the condition of the lawn. If mowing has been delayed and the grass has been allowed to grow in excess of 4", mulching is not recommended. Mow using the side discharge to reduce the grass height to 3 1/4" maximum before mulching.

SECTION 6: MAKING ADJUSTMENTS



WARNING: Do not at any time make any adjustments without first stopping engine and disconnecting spark plug wire.

Handle Height Adjustment

Your mower is shipped with the handle in the higher height position. To lower the height proceed as follows:

- Remove the starter rope from the rope guide.
- Remove the upper handle by removing the hand knobs and carriage bolts. Lay the upper handle out of the way, being careful not to bend or kink the cables.
- Remove the hairpin clips from the weld pins on the handle brackets and remove the wing nuts and carriage bolts from the upper hole on the handle mounting bracket. Press out on the legs of the lower handle and remove lower handle from the mower.
- Turn lower handle around so the notch on the bottom of the lower handle is facing forward. See Figure 10.
- Reassemble, placing the bottom holes in the handle over the weld pins in the handle mounting bracket.
- Place the hairpin clips in the inner holes in the weld pins and insert the carriage bolts the upper hole on

the handle mounting bracket and secure with plastic wing nuts.

- Reassemble the upper handle to the lower handle.
- Attach the starter rope as instructed in the Assembly Section.

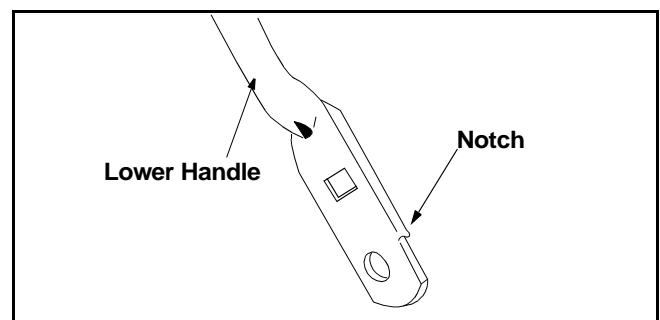

Figure 10

Cutting Height Adjustment

An adjusting plate and spring lever at each wheel position provides cutting height adjustment. Each adjusting plate has assorted height positions. When the spring lever is moved from one location to another the height of cut will be changed. Simply depress the lever towards wheel and move lever assembly to desired position. See Figure 11.

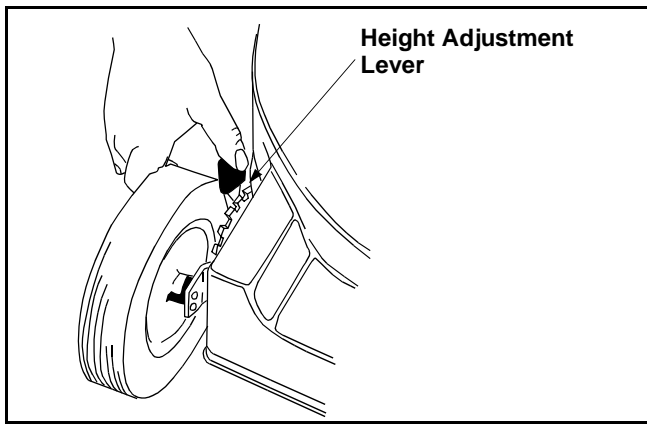

Figure 11

IMPORTANT: All wheels must be placed in the same relative position. For rough or uneven lawns, move the height adjustment lever to a higher position. This will help stop scalping of the grass.

Engine Adjustments

See the separate engine manual packed with your unit for adjustments to the engine.

SECTION 7: MAINTAINING YOUR LAWN MOWER

General Recommendations

- Always observe safety rules when performing any maintenance.
- The warranty on this lawn mower does not cover items that have been subjected to operator abuse or negligence. To receive full value from the warranty, operator must maintain the lawn mower as instructed in this manual.
- Changing of engine governed speed will void engine warranty.
- Some adjustments will have to be made periodically to maintain your unit properly. All adjustments in the Making Adjustments section of this manual should be checked at least once each season.
- Periodically check all fasteners and make sure these are tight.
- Follow the maintenance schedule under Customer Responsibilities to get quality performance from your lawn mower.

Customer Responsibilities

MAINTENANCE SCHEDULE		SERVICE DATES										
		After each use	Every 25 hours	Every 50 hours	Every 100 hours	Once a season	Before storage					
PRODUCT	Lubricate Wheels					✓						
	Lubricate Blade Control					✓						
	Clean Deck	✓					✓					
	Blade Care		✓				✓					
ENGINE	Check Oil	✓										
	Change Oil		✓				✓					
	Replace Air Filter				✓							
	Clean Engine	✓					✓					
	Check Spark Plug			✓		✓						
	Check Spark Arrestor (if any)			✓								

Lubrication



Always stop engine and disconnect spark plug wire before cleaning, lubricating or doing any kind of service work on the lawn mower.

Blade Control: Lubricate the pivot points on the blade control handle and the brake cable at least once a season with light oil. The blade control must operate freely in both directions. See Figure 12.

Rear & Side Discharge Doors: The torsion springs and pivot points should be lubricated periodically with light oil to prevent any rust or binding. Door must work freely.

Wheels: The wheels require no lubrication. However, if the wheels are removed for any reason, lubricate the surface of the axle bolt and the inner surface of the wheel with light oil. Engine oil may also be used.

Engine: Follow engine manual for instruction and schedule of lubrication.

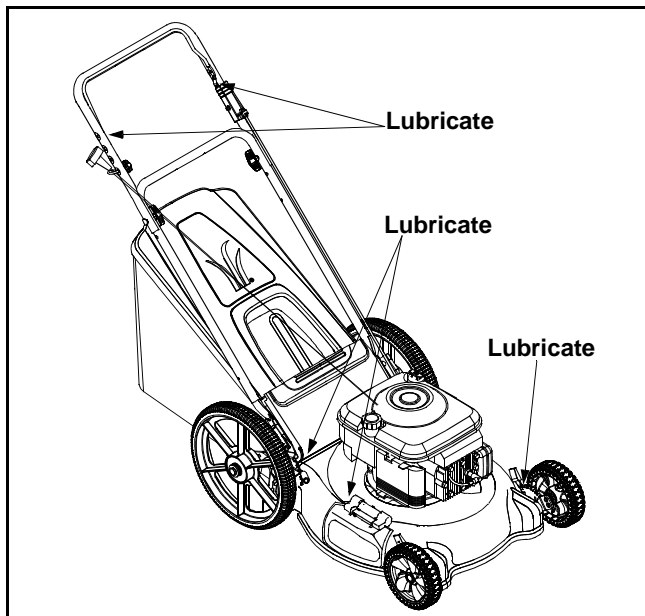

Figure 12

Maintenance

NOTE: When tipping the unit or emptying the fuel tank keep the air cleaner side of engine up. Never tip the mower more than 90 degrees and do not leave the mower tipped for any length of time. Oil can drain into the upper part of the engine causing a starting problem.

Replacing Rear Flap

- To remove rear flap, cut off the flat end of the wire rod which secures it to the deck. See Figure 13.
- Attach the new flap and new rod to deck, bending the ends of the new rod over to secure to deck

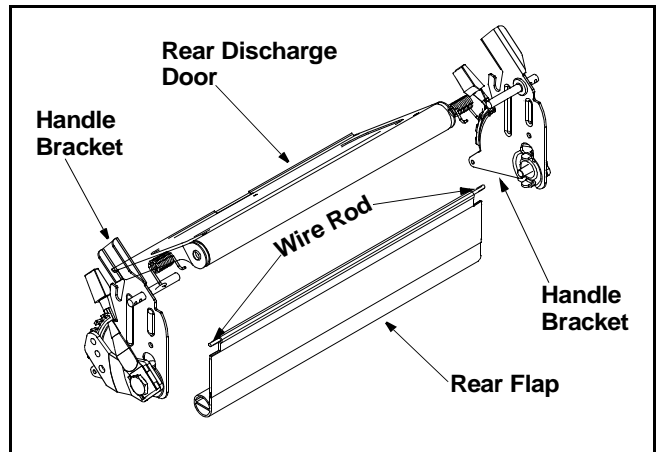

Figure 13

Engine

Refer to the separate engine manual for all engine maintenance instructions.

- Maintain engine oil as instructed in the separate engine manual packed with your unit.
- Service air cleaner every 25 hours under normal conditions. Poor engine performance and flooding usually indicate that the air cleaner should be serviced. To service the air cleaner, refer to the separate engine manual packed with your unit.
- The spark plug should be cleaned and the gap reset once a season. Spark plug replacement is recommended at the start of each mowing season.
- Clean the engine regularly with a cloth or brush. Keep the cooling system (blower housing area) clean to permit proper air circulation which is essential to engine performance and life. Be certain to remove all grass, dirt, and combustible debris from muffler area.

Deck

The underside of the mower deck should be cleaned after each use to prevent a buildup of grass clippings, leaves, dirt, or other matter. If this debris is allowed to accumulate, it will invite rust and corrosion, and may prevent proper mulching, discharge, or bagging. The deck may be cleaned by tilting the mower and scraping clean with a suitable tool (make certain the spark plug wire is disconnected).

IMPORTANT: We do not recommend the use of a pressure washer or garden hose to clean your unit. The use of water will result in shorten life and reduce serviceability.

Cutting Blade Removal, Replacement, and Sharpening

- When removing the cutting blade for sharpening or replacement, protect your hands with a pair of heavy gloves or use a heavy rag to hold the blade.
- Remove the bolt and the blade bell support which hold the blade and the blade adapter to the engine crankshaft. See Figure 14.

- Remove the blade and the adapter from the crankshaft.

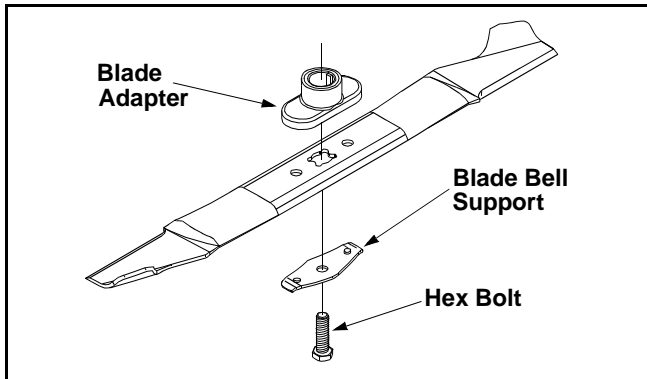

Figure 14



WARNING: Periodically inspect the blade adapter for cracks, especially if you strike a foreign object. Replace when necessary.

When sharpening the blade, follow the original angle of grind as a guide. It is extremely important that each cutting edge receives an equal amount of grinding to prevent an unbalanced blade. An unbalanced blade will cause excessive vibration when rotating at high speeds. It may cause damage to the mower, and could break causing personal injury.

The blade can be tested by balancing it on a round shaft screwdriver. Remove metal from the heavy side until it balances evenly. It is recommended that the blade always be removed from the adapter when testing for balance. Before reinstalling the blade and the blade adapter to the unit, lubricate the engine crankshaft and the inner surface of the blade adapter with light oil.

- Be sure to install the blade with the side of the blade marked "Bottom" (or with part number) facing the ground when the mower is in the operating position.

- Slide the blade adapter onto the engine crankshaft.
- Place the blade on the adapter. Be certain the blade is aligned and seated on the blade adapter flanges.
- Place blade bell support on blade. Make sure the notches on the blade bell support are aligned with small holes in the blade.
- Replace hex bolt and tighten hex bolt to torque: 450 in. lbs. min., 600 in. lbs. max.

NOTE: To ensure safe operation of your mower, the blade bolt must be checked periodically for correct torque.

Storing your Lawn Mower

The following steps should be taken to prepare your lawn mower for storage.

- Clean and lubricate mower thoroughly as described in the lubrication instructions.

IMPORTANT: We do not recommend the use of a pressure washer or garden hose to clean your unit.

- Refer to engine manual for correct engine storage instructions.
- Coat mower's cutting blade with chassis grease to prevent rusting.
- Store mower in a dry, clean area. Do not store next to corrosive materials, such as fertilizer.

NOTE: When storing any type of power equipment in a poorly ventilated or metal storage shed, care should be taken to rust-proof the equipment. Using a light oil or silicone, coat the equipment, especially cables and all moving parts.

SECTION 8: TROUBLESHOOTING

Problem	Cause	Remedy
Engine fails to start	<ol style="list-style-type: none"> 1. Blade control handle disengaged. 2. Spark plug wire disconnected. 3. Fuel tank empty or stale fuel. 4. Blocked fuel line. 5. Faulty spark plug. 6. Engine flooded 	<ol style="list-style-type: none"> 1. Engage blade control handle. 2. Connect wire to spark plug. 3. Fill tank with clean, fresh gasoline. 4. Clean fuel line. 5. Clean, adjust gap, or replace. 6. Wait a few minutes to restart, but do not prime.
Engine runs erratic	<ol style="list-style-type: none"> 1. Spark plug wire loose. 2. Blocked fuel line or stale fuel. 3. Vent in gas plugged. 4. Water or dirt in fuel system. 5. Dirty air cleaner. 6. Carburetor out of adjustment. 	<ol style="list-style-type: none"> 1. Connect and tighten spark plug wire. 2. Clean fuel line; fill tank with clean, fresh gasoline 3. Clear vent. 4. Drain fuel tank. Refill with fresh fuel. 5. Clean air cleaner. 6. Adjust carburetor.
Engine overheats	<ol style="list-style-type: none"> 1. Engine oil level low. 2. Air flow restricted. 3. Carburetor not adjusted properly. 	<ol style="list-style-type: none"> 1. Fill crankcase with proper oil. 2. Remove blower housing and clean. 3. Adjust carburetor.
Occasional skip (hesitates) at high speed	<ol style="list-style-type: none"> 1. Spark plug gap too close. 	<ol style="list-style-type: none"> 1. Adjust gap to .030".
Idles poorly	<ol style="list-style-type: none"> 1. Spark plug fouled, faulty or gap too wide. 2. Carburetor improperly adjusted. 3. Dirty air cleaner. 	<ol style="list-style-type: none"> 1. Reset gap to .030" or replace spark plug. 2. Adjust carburetor. 3. Clean air cleaner.
Excessive vibration	<ol style="list-style-type: none"> 1. Cutting blade loose or unbalanced. 2. Bent cutting blade. 	<ol style="list-style-type: none"> 1. Tighten blade and adapter. Balance blade. 2. Replace blade.
Mower will not mulch grass	<ol style="list-style-type: none"> 1. Wet grass. 2. Excessively high grass. 3. Dull blade. 	<ol style="list-style-type: none"> 1. Do not mow when grass is wet; wait until later to cut. 2. Mow once at a high cutting height, then mow again at desired height or make a narrower cutting path. 3. Sharpen or replace blade.
Uneven cut	<ol style="list-style-type: none"> 1. Wheels not positioned correctly. 2. Dull blade. 	<ol style="list-style-type: none"> 1. Place all four wheels in same height position. 2. Sharpen or replace blade.

NOTE: For repairs beyond the minor adjustments above, contact your local authorized service dealer.

Notes

Model Series 540

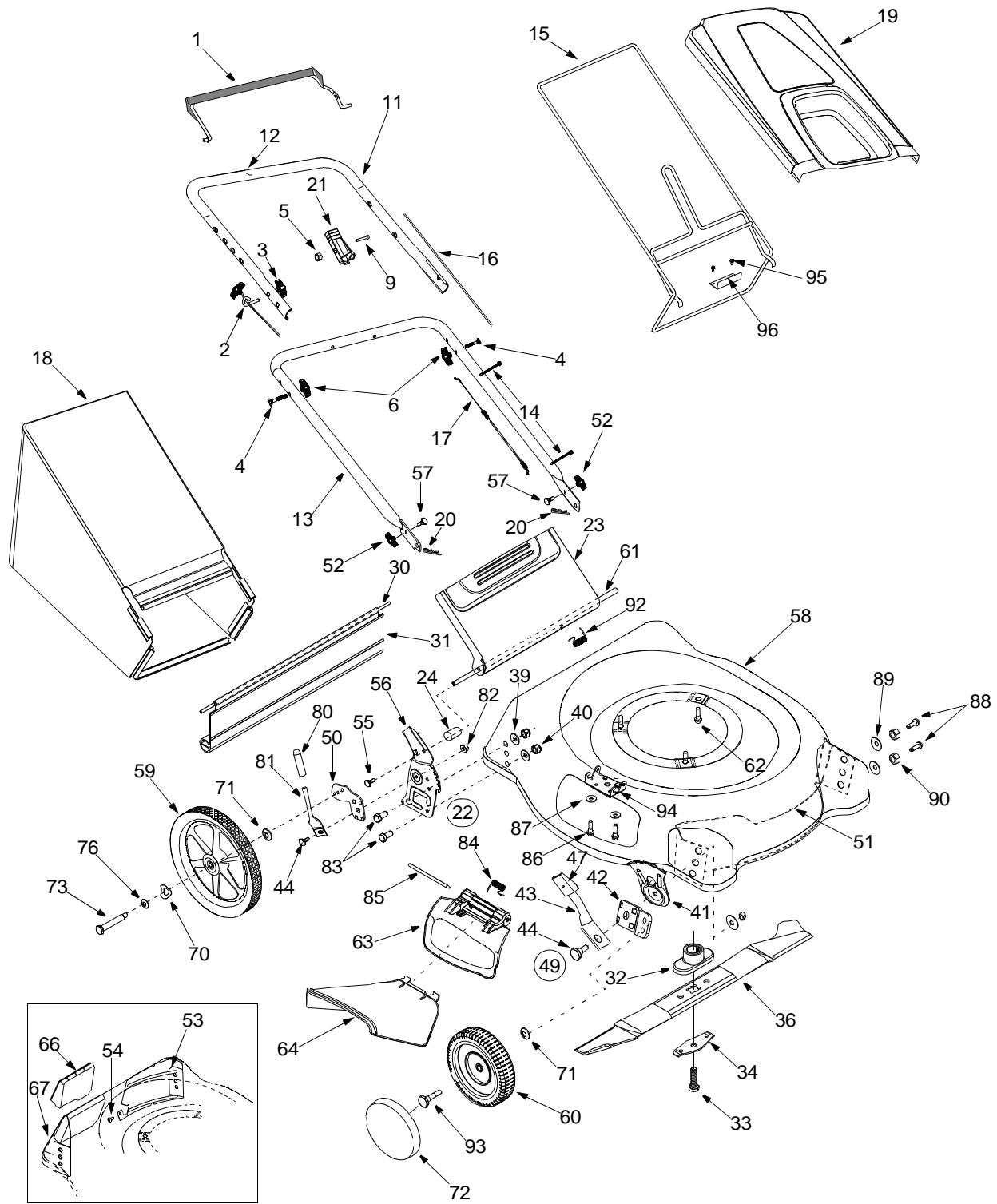

Model Series 540

Ref. No.	Part No.	Part Description	Ref. No.	Part No.	Part Description
1.	747-0824	Control Handle Assembly	50.	17488A	Pivot Bar - RH
	647-0004	Deluxe Control Handle		17489A	Pivot Bar - LH
2.	710-1205	Rope Guide	51.	782-5002	Front Baffle
3.	720-0279	Handle Knob	52.	712-0397	Wing Knob
4.	710-1174	Curved Hd. Bolt 5/16-18 x 2"	53.	782-5003	Rear Baffle
5.	712-0324	Hex L-Nut 1/4-20 Thd.	54.	710-1017	Torx Mach. AB-Tap Scr.
6.	720-0314	Hand Knob	55.	710-0896	Hex Washer Screw 1/4-14 x .625
9.	710-1270	Screw 1/4-20 x 1.31	56.	682-3058	Handle Bracket Assembly—R.H.
11.	749-0438C	Upper Handle		682-3059	Handle Bracket Assembly—L.H.
12.	720-0295	Foam Grip †	57.	710-0703	Carriage Bolt, 1/4-20 x .75"
13.	749-0907A	Lower Handle	58.	782-0047	Deck 21"
14.	726-0240	Cable Tie	59.	734-1860	Rear Wheel Ass'y 14 x 2
15.	747-0995A	Catcher Frame		734-1864	Rear Wheel Ass'y. 14 x 1.8
16.	746-0550	Control Cable 39"	60.	734-1818	Front Wheel Ass'y. 8 x 2
	746-0737	Control Cable 51"		734-1781	Front Wheel Ass'y 8 x 1.75
17.	746-0841	Throttle Cable 60" †		734-1841	Front Wheel Ass'y 8 x 1.7
	746-0847	Throttle Cable 42" †		734-1987	Front Wheel Assembly 8 x 1.8
18.	664-0084	Grass Bag w/o logo	61.	747-0996	Chute Door Pivot Rod
	664-0085	Grass Bag w/ logo, Yellow	62.	710-0654A	Sems Screw TT 3/8-16 x 1
	664-0086	Grass Bag w/ logo, Red	63.	682-7000	Mulching Plug
19.	731-0066	Hard Top w/ logo	64.	731-1409	Chute Deflector
	731-0068	Hard Top w/o logo	66.	782-5007A	Rear Mulch Plug
20.	714-0104	Internal Cotter Pin	67.	782-5004	Rear Mulch Baffle
21.	746-0883	Throttle Housing w/o Lever	70.	736-0182	Wave Washer
22.	682-3058	Handle Bracket Assembly - RH	71.	736-0105	Spring Washer
	682-3059	Handle Brkt Ass'y - LH (Not Shown)	72.	731-1426	Hub Cap †
23.	782-7599A	Grass Bag Door	73.	738-0481A	Rear Axle Bolt
24.	750-0434	Spacer .375 OD x .50 ID x 1.02"	76.	736-0456	Flat Washer
30.	732-0700	Wire Rod	80.	720-0312	Foam Grip
31.	731-1236	Rear Flap	81.	732-0866	Height Adj. Lever
32.	753-0588	Blade Adapter Kit	82.	712-3005	Hex Flange Lock Nut 3/8-16
33.	710-1044	Hex Bolt 3/8-24 x 1.5"	83.	710-0514	Hex Cap Screw 3/8-16 x 1.0
34.	736-0524A	Blade Bell Support	84.	732-0731	Torsion Spring
36.	742-0741	Mulching Blade	85.	747-0710	Hinge Pin
39.	736-0356	Bell Washer .39" I.D. x 1.38"	87.	736-0270	Bell Washer .265 x .75 x .062
40.	712-0130	Hex Lock Nut 3/8-16	88.	710-0216	Hex Screw 3/8-16 x .75
41.	15261A	Height Adj. Plate	89.	736-0331	Bell Washer .39 x 1.13 x .062
42.	15262B	Pivot Bar	90.	712-0798	Hex Nut 3/8-16
43.	732-0404	Spring Lever: Front Wheel	92.	732-0809	Torsion Spring
44.	738-0507B	Shoulder Bolt .5" Dia. x .357"	93.	738-0102	Front Axle Bolt
47.	720-0190	Spring Lever Knob	94.	782-7006	Hinged Mounting Bracket
49.	14578	Height Adj. Assembly Comp - RH	95.	710-0896	Hex Screw 1/4-14 x .625
	14579	Height Adj. Assembly Comp - LH	96.	782-9050	Mounting Bracket

† If Equipped

MANUFACTURER'S LIMITED WARRANTY FOR:



The limited warranty set forth below is given by MTD PRODUCTS INC ("MTD") with respect to new merchandise purchased and used in the United States, its possessions and territories.

MTD warrants this product against defects in material and workmanship for a period of two (2) years commencing on the date of original purchase and will, at its option, repair or replace, free of charge, any part found to be defective in material or workmanship. This limited warranty shall only apply if this product has been operated and maintained in accordance with the Operator's Manual furnished with the product, and has not been subject to misuse, abuse, commercial use, neglect, accident, improper maintenance, alteration, vandalism, theft, fire, water or damage because of other peril or natural disaster. Damage resulting from the installation or use of any accessory or attachment not approved by MTD Products Inc. for use with the product(s) covered by this manual will void your warranty as to any resulting damages.

Normal wear parts or components thereof are subject to separate terms as follows: All normal wear part or component failures will be covered on the product for a period of 90 days regardless of cause. After 90 days, but within the two year period, normal wear part failures will be covered ONLY IF caused by defects in material or workmanship of OTHER component parts. Normal wear parts and components include, but are not limited to, belts, blades, blade adapters, grass bags, rider deck wheels, seats, snow thrower skid shoes, shave plates and tires. Batteries are covered by a 90-day limited replacement warranty.

HOW TO OBTAIN SERVICE: Warranty service is available, WITH PROOF OF PURCHASE THROUGH YOUR LOCAL AUTHORIZED SERVICE DEALER. To locate the dealer in your area, please check for a listing in the Yellow Pages or contact the Customer Service Department of MTD PRODUCTS INC by calling 1-800-800-7310 or writing to P.O. Box 368022, Cleveland, Ohio 44136-9722.

This limited warranty does not provide coverage in the following cases:

- a. The engine or component parts thereof. These items carry a separate manufacturer's warranty. Please refer to the applicable manufacturer's warranty on these items.
- b. Log splitter pumps, valves and cylinders have a separate one year warranty.

c. Routine maintenance items such as lubricants, filters, blade sharpening and tune-ups, or adjustments such as brake adjustments, clutch adjustments or deck adjustments; and normal deterioration of the exterior finish due to use or exposure.

d. MTD does not extend any warranty for products sold or exported outside of the United States of America, its possessions and territories, except those sold through MTD's authorized channels of export distribution.

No implied warranty, including any implied warranty of merchantability or fitness for a particular purpose, applies after the applicable period of express written warranty above as to the parts as identified. No other express warranty or guaranty, whether written or oral, except as mentioned above, given by any person or entity, including a dealer or retailer, with respect to any product shall bind MTD. During the period of the Warranty, the exclusive remedy is repair or replacement of the product as set forth above. (Some states do not allow limitations on how long an implied warranty lasts, so the above limitation may not apply to you.)

The provisions as set forth in this Warranty provide the sole and exclusive remedy arising from the sales. MTD shall not be liable for incidental or consequential loss or damages including, without limitation, expenses incurred for substitute or replacement lawn care services, for transportation or for related expenses, or for rental expenses to temporarily replace a warranted product. (Some states do not allow the exclusion or limitation of incidental or consequential damages, so the above exclusion or limitation may not apply to you.)

In no event shall recovery of any kind be greater than the amount of the purchase price of the product sold. Alteration of the safety features of the product shall void this Warranty. You assume the risk and liability for loss, damage, or injury to you and your property and/or to others and their property arising out of the use or misuse or inability to use the product.

This limited warranty shall not extend to anyone other than the original purchaser, original lessee or the person for whom it was purchased as a gift.

How State Law Relates to this Warranty: This limited warranty gives you specific legal rights, and you may also have other rights which vary from state to state.